



FEATURES

Foot Pedal Control
 2 way rotation
 Optional internal skiving tools
 CE Certified
 Compact Design

OPTIONS

110V/220V 1 Phase
 230V/440V/480V 3 Phase

CONTROL

By foot pedal

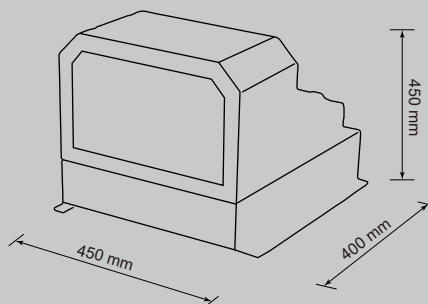

SKIVER 51DF

TECHNICAL DATA

Hose capacity, external (inch)	3/16-2
Hose capacity, internal (inch)	3/8-2
Speed of tool rotation (r./min)	100
Skiving length (mm)	100
Motor Power (KW/HP)	0.75/1.0(400V 3 Phase)

DIMENSIONS (LxWxH)

Machine (mm)	450x400x450
Machine (inch)	17.7x15.7x17.7
Packaged (mm)	550x500x550
Packaged (inch)	21.7x19.7x21.7

WEIGHT

Machine (kg/lbs)	40/88
Packaged (kg/lbs)	70/154

DESCRIPTION	Pno	Size (inches)
INTERNAL TOOLS	715078	3/8
	708937	1/2
	707182	5/8
	707167	3/4
	707166	1
	707179	1 1/4
	707181	1 1/2
EXTERNAL MANDRELS	707184	2
	711313	3/16
	711312	1/4
	711311	5/16
	711310	3/8
	711321	1/2
	711320	5/8
	711319	3/4
	711318	1
	711314	1 1/4
711315	1 1/2	
711317	2	
TOOL RACK WITHOUT TOOLS	707253	
TOOL RACK + MANDRELS	711331	

Products images & Specifications may alter prior official notice at any time.